



Models 40-120, 40-125

SPECIFICATIONS

TYPE OF CIRCUIT:

Models 40-120 and 40-125 are six (6) tube super-heterodyne receivers employing the new Philco built-in super aerial system which eliminate an outside aerial, and Philco High-Efficiency Loktal tubes. In addition, other features of design are: two tuning ranges; special high gain R. F. stage; automatic volume control and a Beam power audio output stage. In general, these models are similar but differ in their tuning mechanisms and cabinets.

Model 40-120 is dial tuned and assembled in cabinet type "C".

Model 40-125 is equipped with six electric push buttons for automatically selecting stations in addition to dial tuning. Five push buttons are used for stations one of which can be used in combination with a Special type PHILCO TELEVISION receiver for reception of television sound programs. The sixth push button selects dial tuning. The procedure for

adjusting and operating push button tuning will be found in the instructions supplied with each receiver. Instructions for setting up the television push button is supplied with Philco Television Receivers. This model is assembled in special type "C" cabinet.

TUNING RANGE: 540 to 1600 K. C. 1.6 to 3.3 M. C.

INTERMEDIATE FREQUENCY: 455 K. C.

POWER SUPPLY: 115 volts A. C. or D. C. current.

POWER CONSUMPTION: 28 watts.

AUDIO OUTPUT: 1 watt.

PHILCO TUBES USED:

7C7, R. F.; 7A8, oscillator and first detector; 7B7, I. F.; 7C6, second detector, first audio; 35A5, output; 35Z3, rectifier.

CABINET DIMENSIONS:	Height	Width	Depth
Model 40-120.....	6 ¹ / ₁₆	1 ¹ / ₈	6 ¹ / ₁₆
Model 40-125.....	7 ¹ / ₁₆	11	6 ⁵ / ₁₆

ALIGNMENT OF DIAL TUNING COMPENSATORS

EQUIPMENT REQUIRED:

(1) Signal Generator; Philco Model 077 Signal Generator which has a fundamental frequency range from 115 to 36,000 K. C. is the correct instrument for this purpose.

(2) Output Meter; Philco Models 027 or 028 Vacuum Tube Voltmeters and Circuit Testers incorporate a sensitive output meter and are recommended.

(3) Philco Fiber Handle Screw Driver, Part No. 45-2610. Aligning adapter Part No. 45-2767.

OUTPUT METER: The Philco 027 or 028 Output Meter is connected to the plate and screen terminals of the type 35A5 tube and adjusted for the 0 to 30 V. A. C. scales.

VACUUM TUBE VOLTMETER: To use the vacuum tube voltmeter as an alignment indicator make the following connections:

Remove the 7C6 tube from its socket and insert the aligning adapter, Part No. 45-2767, then replace the tube in the adapter. Connect the negative terminal of the vacuum tube voltmeter to the wire which protrudes from the side of the adapter. Attach the positive terminal of the voltmeter to the chassis. The positive terminal is connected to the chassis.

After connecting the output meter, adjust the compensators in the order as shown in the tabulation below. Locations of the compensators are shown on Fig. 2. If the output meter pointer goes off scale when adjusting the compensators, reduce the strength of the signal from the generator.

Operations in Order	SIGNAL GENERATOR			RECEIVER			SPECIAL INSTRUCTIONS
	Output Connections to Receiver	Dummy Antenna Note A	Dial Setting	Dial Setting	Control Settings	Adjust Compensators in Order	
1	7C7 See Note C	.1 mf.	455 K. C.	580 K. C.	Vol. Cont. Max.	14A, 14B, 15A	Push "IN" Manual Button Model 40-125
2	Ant. Ter.	10 mmf.	1600 K. C.	1600 K. C.	Vol. Cont. Max.	2B	See Note B See Note C
3	Ant. Ter.	10 mmf.	1400 K. C.	1400 K. C.	Vol. Cont. Max.	2A	

NOTE A — The "Dummy Antenna" consists of a condenser connected in series with the signal generator output lead (High side). Use the capacity or resistance as specified in each step of the above procedure.

NOTE B — **DIAL CALIBRATION:** In order to adjust the receiver correctly, the dial must be aligned to track properly with the tuning condenser. To do this, proceed as follows: Turn the tuning condenser to the maximum capacity position (plates fully meshed). With the condenser in this position, the tuning pointer is set horizontal at the low frequency end of the scale (540 K. C.).

NOTE C — Compensators 2A and 2B are at the top of the tuning condenser. Compensator 2A is on the front section and compensator 2B on the rear section. When padding the I. F. the signal generator can be attached to the 7C7 grid on the front section of the tuning condenser.

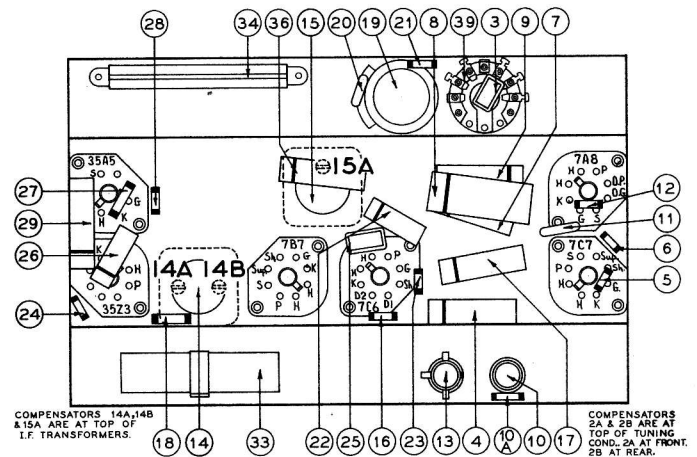
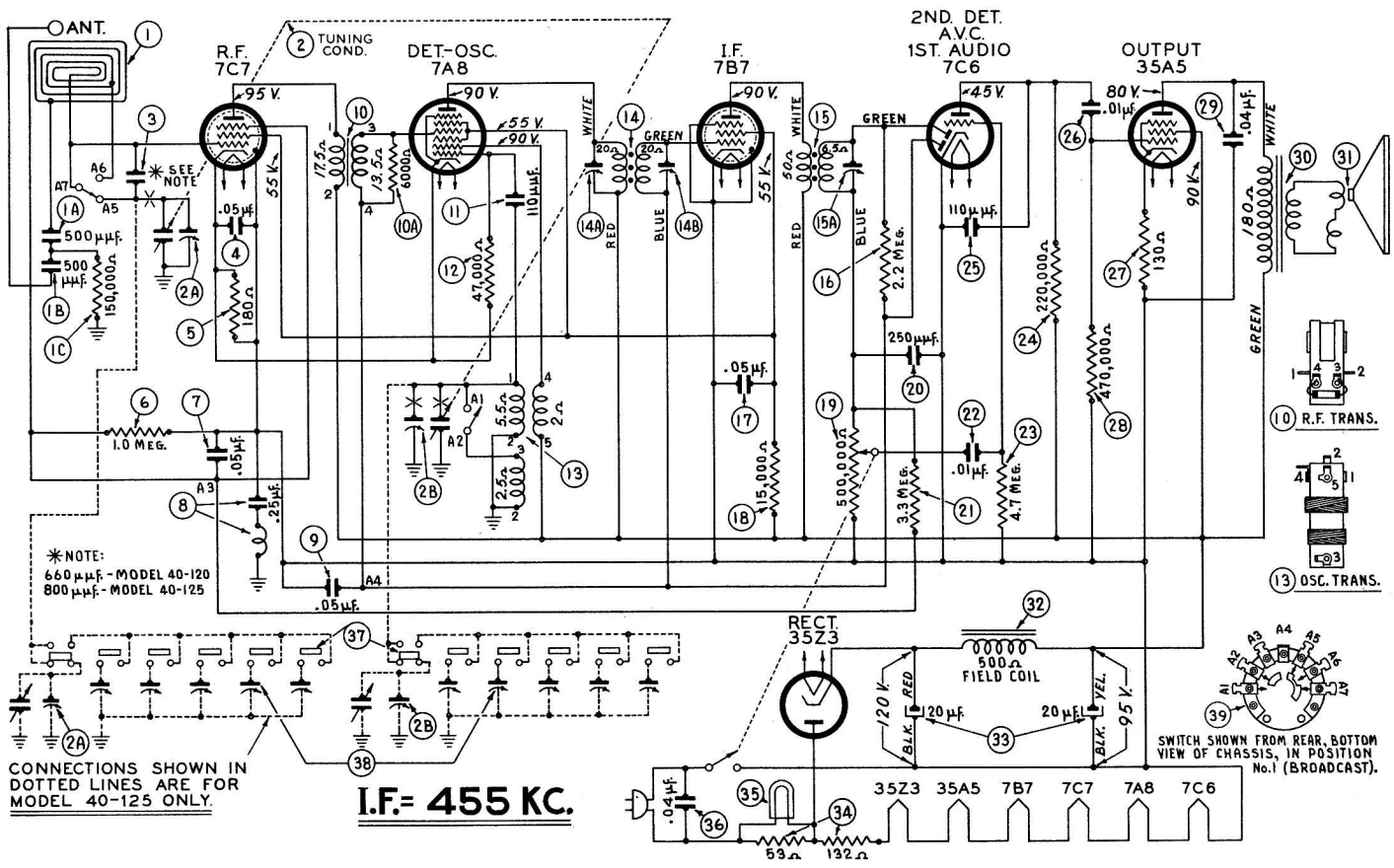

Fig. 1



SCHMATIC DIAGRAM MODELS 40-120 & 40-125

Fig. 2

REPLACEMENT PARTS

SCHE. No.	DESCRIPTION	PART No.	SCHE. No.	DESCRIPTION	PART No.	SCHE. No.	DESCRIPTION	PART No.
1	Loop Antenna Assy. (Model 40-120)	38-9889	16	Resistor (2.2 meg., 1/2 watt)	33-522339	36	Tubular Cond. (.04 mfd.)	30-4119
1A	Mica Cond. (500 mmfd.)	30-1114	17	Tubular Cond. (.05 mfd.)	30-4519	37	Push Button Switch (Model 40-125)	42-1512
1B	Mica Cond. (500 mmfd.)	30-1114	18	Resistor (15,000 ohms, 1/2 watt)	33-315339	38	Padder Strip (Model 40-125)	31-6312
1C	Resistor (150,000 ohms, 1/2 watt)	33-415339	19	Volume Control & On-Off Switch	33-53396	39	Wave Switch	42-1505
2	Tuning Cond. Assy. (Model 40-120)	31-2388	20	Mica Cond. (250 mmfd.)	30-1074		Cable & Plug (Power Supply)	L-3199
	(Model 40-125)	31-2397	21	Resistor (3.3 meg., 1/2 watt)	33-533339		Cabinet (Model 40-120)	10389A
3	Mica Cond. (660 mmfd., Model 40-120)	30-1136	22	Tubular Cond. (.01 mfd.)	30-4479		Clip (Coil Mtg.)	28-5002
	(800 mmfd., Model 40-125)	30-1135	23	Resistor (4.7 meg., 1/2 watt)	33-547339		Dial	27-5517
4	Tubular Cond. (.05 mfd.)	30-4519	24	Resistor (220,000 ohms, 1/2 watt)	33-422339		Drive Cord Assy.	31-2387
5	Resistor (180 ohms, 1/2 watt)	33-118339	25	Mica Cond. (.110 mmfd.)	30-1135		Drive Shaft Assy.	31-2370
6	Resistor (1.0 meg., 1/2 watt)	33-510339	26	Tubular Cond. (.01 mfd.)	30-4572		Knobs (Volume-Tuning-Wave Switch)	27-4809
7	Tubular Cond. (.05 mfd.)	30-4519	27	Resistor (130 ohms, 1/2 watt)	33-113336		Pilot Lamp Socket Assy.	38-9825
8	Tubular Cond. & Choke Assy. (.25 mfd.)	38-9851	28	Resistor (470,000 ohms, 1/2 watt)	33-447339		Pointer (Dial)	27-4845
9	Tubular Cond. (.05 mfd.)	30-4519	29	Tubular Cond. (.04 mfd.)	30-4119		Pointer (Knob)	56-1465
10	R. F. Trans. Assy.	32-3273	30	Output Trans. (Spkr. Part No. 36-1469-1)	32-8047		Spring (Drive Cord Assy.)	28-8954
10A	Resistor (6000 ohms, 1/2 watt)	33-260339		(Spkr. Part No. 36-1469-9)	32-8044		Speaker Assy.	36-1469
11	Mica Cond. (.110 mmfd.)	30-1130	31	Cone & Voice Coil Assy. (Spkr. Part No. 36-1469-1)	36-4115		Sockets (Loktal)	55-0575
12	Resistor (47,000 ohms, 1/2 watt)	33-347339		(Spkr. Part No. 36-1469-9)	36-4113			
13	Oscillator Trans. (Model 40-120)	32-3255	32	Field Coil (Replace Spkr. Part No. 36-1469)	36-4113			
	(Model 40-125)	32-3256	33	Electrolytic Cond. (20-20 mfd.)	30-2403			
14	1st I. F. Trans. Assy.	32-3237	34	Filament Resistor	33-3375			
15	2nd I. F. Trans. Assy.	32-3238	35	Pilot Lamp	34-2068			

MISCELLANEOUS PARTS—MODEL 40-125

	Cabinet	10390A
	Escutcheon Plate (Pushbutton)	28-5742
	Escutcheon Pins	W-1074
	Knobs (Pushbutton)	27-4824
	Tab (Dial)	27-5526
	Tab Kit	40-6473

MANY OF THE PARTS IN THIS PHILCO, SUCH AS CONDENSERS AND RESISTORS, ARE HELD TO MUCH CLOSER TOLERANCE THAN STANDARD REPLACEMENT PARTS. GENUINE PHILCO REPLACEMENT PARTS MUST BE USED TO OBTAIN SATISFACTORY PERFORMANCE OF THIS MODEL.

Philco Radio and Television Corp.

PARTS AND SERVICE DIVISION

Philadelphia, Pa.